

E520L1130; E520L1140

5" 1100 Lumen LED Square Reflector Engine



PROJECT INFORMATION:

Project Name: _____

Fixture Type: _____

Date: _____

DIMENSIONS

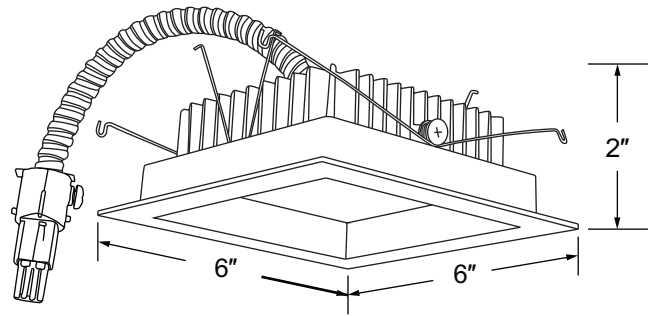
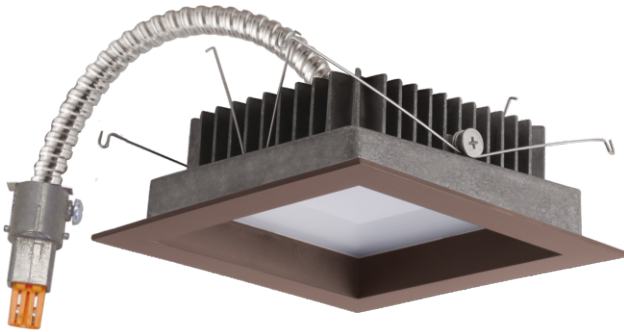

PRODUCT SPECIFICATIONS

- Suitable for use in fixtures installed in insulated ceilings
- Suitable for installation into a 5" square recessed fixtures with 2-wire connector (EL5SQLFU11)
- Meets restricted airflow requirements per ASTM E-283
- CA Title 24 Compliant (JA8-2016)
- Meets ENERGY STAR requirements.

Lamp: LED Array, CRI 90+

E520L1130: 16W, 3000K, 1100 lm

E520L1140: 16W, 4000K, 1100 lm

Life-span: 50,000 hours

Labels: UL listed for Wet Location

Finishes: White, Bronze, Black

Warranty: 5 years limited

CATALOG NUMBER

Example: E520L1130W
E520L1140W
E520L1130B
E520L1140B
E520L1130BZ
E520L1140BZ